

APPROPRIATE LENGTHS BETWEEN PHALANGES OF MULTIJOINTED FINGERS FOR STABLE GRASPING

Tokuji Okada and Takeo Kanade

Robotics Institute
Carnegie-Mellon University, Schenley Park, Pittsburgh, PA 15213

ABSTRACT

An appropriate arrangement of finger joints is very important in designing multijointed fingers since the stability of grasping an object greatly depends on that arrangement. Multijointed fingers can grasp an object with many points of contact each of which is pressed against the object as if wrapping up that object. The amount of the wrapped up area and the form of the finger when an object is grasped are therefore important factors for determining the stability of the grasping. We propose the wrap-up rate to be used for the evaluation of the stability of grasping by using these factors. We consider twenty eight models for the finger having three joints, and perform a simulation of their ability to grasp various shapes stably. Based on the simulation results, an appropriate arrangement of lengths between phalanges for a multijointed finger is presented.

I INTRODUCTION

Two kinds of end effectors for grasping an object have been developed: One is the gripper and the other is the multijointed finger. Most grippers have simple mechanisms and grasp an object by pinching it since the grippers can only close and open. Although, the grippers are useful for grasping objects of limited shape and size, controlling the pressing force of the fingers against the object would make those grippers more versatile (Asada, 1979, Rovetta and Franchetti, 1980). Multijointed fingers exhibit this versatility since they have increased mechanical flexibility and are able to grasp objects of a wider variety of shapes and sizes (Okada, Salisbury, 1982). While they are desirable features, the main requirement for grasping objects is that the grip is stable. One way of determining this stability in both types of end effectors is by measuring the force exerted between the fingers and an object. Asada, 1979 and Chen, 1982 studied the problem of achieving a stable grip from this point of view. Multijointed fingers, however, grasp an object in a complex manner and this complexity makes it difficult to determine the stability of grasping based solely on the force between the fingers and object. We propose another method for assessing the stability of grip in multijointed fingers based on their inherent ability to wrap around an object. In a previous paper (Okada, 1973) we used the amount of wrapped up area as a guide to assessing the stability of the grip. However, we considered neither the number of points of contact between the fingers and the object nor the position of the fingers where that contact occurs. Salisbury, 1982 treated contact configurations for

designing a most suitable articulated hand (Stanford/JPL Hand), his treatment, however, was limited to mobilities and connectivities for acceptable hand mechanisms and did not include stability of grasping.

In this paper we examine the number of points of contact between fingers and object in evaluating the stability of grasping. Since this number depend on the arrangement of the joints and the lengths between the phalanges, two criteria are important to the stability of grasping: the amount of the wrapped up area and the form of the fingers including tactual conditions when the object is grasped. Thus, by taking notice of these two criteria, we will evaluate the stability of grasping by multijointed fingers having three joints for the designing of multijointed fingers.

II EVALUATION OF THE GRASPING BY A FORM OF FINGERS

The size of the fingers is determined depending on the sizes of the objects to be handled. After quantifying sizes of fingers and objects, we evaluate the stability of the graspings in the relationships between the objects and the fingers relatively. We will present the criteria which use the configuration of the fingers and tactual conditions.

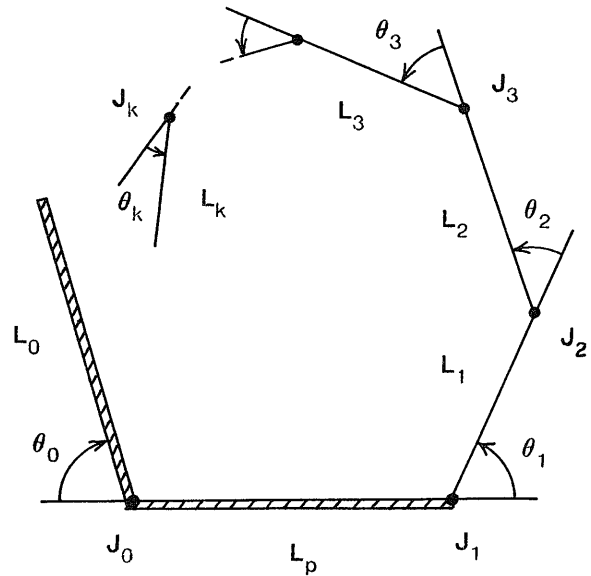

Figure 1: Finger structure.

A. Relationships Between Sizes of Fingers and an Object

The total length of a finger is determined mainly by the size of an object to be grasped. For our purposes, most objects are assumed to be lumps except for pillar-shaped objects. To express the size of the lumps, let the maximum width of an object be W_d , and the minimum width be W_s . When the object is not considered to be a lump, these are measured in the perpendicular plane to the longitudinal axis of the object.

The structure of the multijointed fingers we will consider is shown in Figure 1. In the figure, the multijointed finger moves in one plane and has k links, $L_1, L_2, L_3, \dots, L_k$ which are connected to joint $J_1, J_2, J_3, \dots, J_k$, respectively. The angular values of each joint are denoted by $\theta_1, \theta_2, \theta_3, \dots, \theta_k$. The horizontal link at the bottom is a palm and L_p stands for its length. L_0 is the length of the link which plays an auxiliary role for grasping an object with the multijointed finger. The angular value of the joint J_0 is expressed by θ_0 . The palm L_p is fixed, but the links L_0, L_i ($i = 1, 2, \dots, k$) rotate about the corresponding joints. The ranges of angular rotation of proximal joints J_0 and J_1 are $0 < \theta_0 < \pi$ and $0 < \theta_1 < \pi$, and those for other joints are $0 < \theta_i < \pi/2$ ($i = 2, 3, \dots, k$). Let us denote the total length of the finger as $L_T (= \sum_{i=1}^k L_i)$. It seems reasonable to impose the following three conditions on the relations of L_T, L_p and L_0 :

$$(L_p^2 + L_0^2)^{1/2} < L_T < L_p + L_0, \quad (1)$$

$$W_d < L_T, \quad (2)$$

$$W_s > 2(L_T - L_p)/3. \quad (3)$$

The first condition states that the total length L_T is longer than the length between the tip of L_0 and the joint J_1 when L_1 and the palm make a right angle, and shorter than that when the joint stretches. The total length of the finger should be longer than

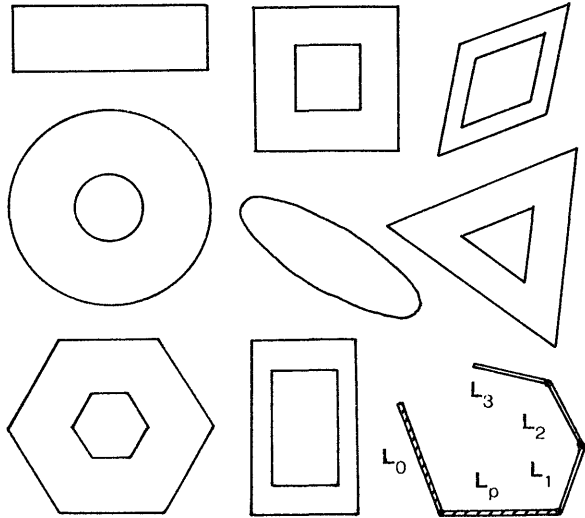

Figure 2: Relationships between the sizes of finger and objects.

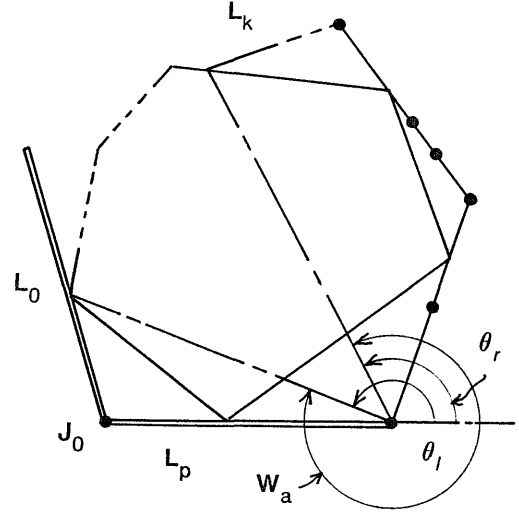

Figure 3: Illustration of the amount of wrap-up.

the maximum width of an object by the second condition. The third condition is understood by considering the case of $k = 3$; the minimum size of an object W_s is larger than the diameter of the circle which touches the links L_0, L_1, L_2 and L_3 (fingertip) when $\theta_0 = \theta_1 = \theta_2 = \theta_3 = \pi/2$.

As the size of the object increases, so the length of the fingers must also increase. Intuitively, the reverse must also be true. The length L_0 would be determined therefore depending on the length of L_p . We quantify this relationship by using μ which is the ratio of L_T to L_p ($\mu = L_T/L_p$). We will investigate the case when $\mu = 1.8$, and $L_0 = L_p$. Figure 2 illustrates the size of the finger relative to that of the objects which satisfy the inequality conditions (1-3). Given the three-jointed finger shown in the lower right, the maximum and minimum sizes that can be handled by the finger are illustrated for each shape. The rectangle and ellipse show the longest and slenderest figures that can be handled.

B. Definition of Wrap-up Rate

In the previous paper (Okada, 1973), the value $\Theta = \theta_0 + \sum_{i=1}^m \theta_i$ was used to evaluate the ability of grasping, where m was the maximum number of link where there was a contact between the object and the finger ($m \leq k$). The point of contact in the fingertip was treated in the same way as the point of contact in the middle point of the link. Also the position of the point of contact on the link L_0 was not considered.

In order to take these factors into account, we define a new measure named a *wrap-up rate* W_r , which can be expressed as follows:

$$W_r = \{2\pi - (\theta_1 - \theta_r)\} / (2\pi), \quad (4)$$

The concept of wrap-up rate is illustrated in Figure 3. In this definition, θ_r is the angular displacement of the point at which the

link L_0 touches the object, and θ_r is the angular displacement of the joint J_1 to the most distal position at which the finger touches the object. When $\theta_i = \theta_r$, the finger wraps the object completely and the value W_r becomes equal to 1. At this value the grip is considered to be most stable. The larger the value of W_r becomes, the more stable grasping the finger provides.

A finger having large values of L_7 and k tends to wrap the finger around the object more than one turn. Under the conditions that $k=3$, $2^{1/2} < \mu < 2$, and equations (1), (2) and (3) are valid, the maximum value of W_r is $1 + \tan^{-1}(L_0/L_p)/2\pi$, which occurs when $\theta_i = \pi - \tan^{-1}(L_0/L_p)$ and $\theta_r = \pi$. If $L_p = L_0$, this maximum value of W_r is 1.125.

III Simulation for Finding Appropriate Lengths between Phalanges

In order to find appropriate finger constructions for the stable grasping of objects having various shapes and sizes, we simulate the graspings and evaluate them by using the wrap-up rate. Various constructions of a finger are considered and various objects are grasped by each construction. The results depend not only on finger constructions but also on the size and shape of the objects. Mutual relationships among these factors are investigated.

A. Control Sequence of Finger

Grasping an object by a finger is realized by the following control sequence. It is important to have the palm L_p touch the object since this contact enables the finger to grasp the object stably. In our sequence of grasping, this contact is required. The control sequence is:

1. Stretch the finger so that $\theta_i = 0$ ($i = 1, 2, \dots, k$). An object is placed on the palm link.
2. Starting with joint J_0 , bend the joints in turn from proximal to distal. Joint J_{i+1} begins to bend when a contact occurs with the object on the link L_i , or when the angular displacement of joint J_i reaches its maximum.
3. Finger control ends either when the final link L_k touches the object or when its angular displacement reaches its maximum while joint J_k bends.

Application of these rules to the finger control results in various types of finger configurations. Configurations of unstable

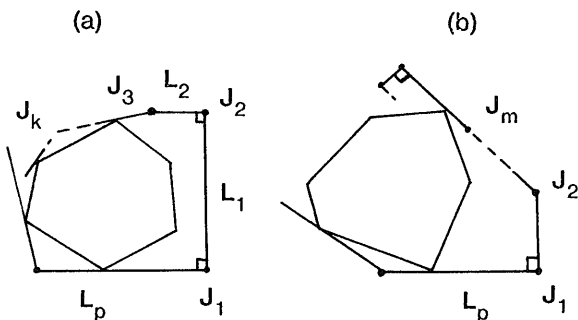

Figure 4: Unstable graspings in general.

TYPE	I	I	I	M	M	M	V	I	I	M	M	M	V	K	M	M	V	D	D	V	D	D	D	D	D			
L_1	1	1	1	1	1	1	2	2	2	2	2	2	3	3	3	3	4	4	4	4	5	5	5	6	6	7		
L_2	1	2	3	4	5	6	7	1	2	3	4	5	6	1	2	3	4	5	1	2	3	4	1	2	3	1	2	1
L_3	7	6	5	4	3	2	1	6	5	4	3	2	1	5	4	3	2	1	4	3	2	1	3	2	1	2	1	1

Table 1: Finger models.

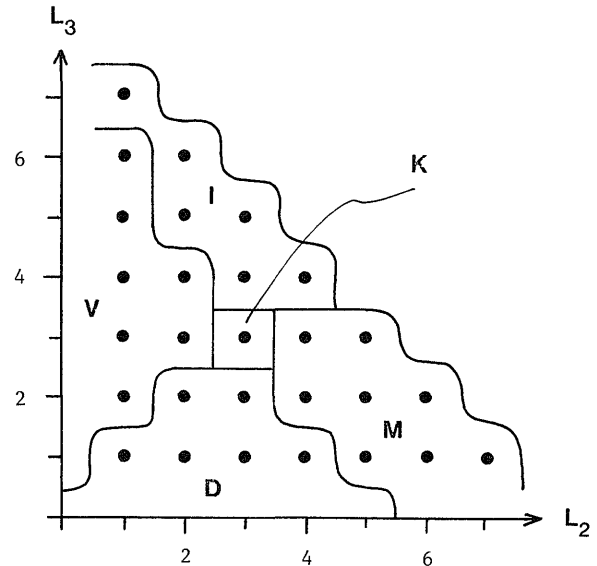

Figure 5: Classification of finger models into five types.

graspings are included too. For instance, those graspings shown in Figure 4 are considered as unstable. The configuration in Fig.4(a) is $\theta_1 = \theta_2 = \pi/2$ [rad], and the object does not touch L_1 and L_2 . Fig.4(b) shows the unstable grasping which occurs when the amount of $\theta_0 + \sum_{i=1}^m \theta_i$ is less than π [rad]. This configuration is not stable since the object has a tendency to move out from the palm area. We exclude these unstable graspings before we calculate the wrap-up rate W_r described in Section II-B.

B. Finger Models

The finger we consider has three joints whose rotational axes are all parallel. Table 1 shows the twenty eight models we considered each of which has different combinations of the lengths of L_1 , L_2 and L_3 . Each number in the table expresses the proportion of the length of a link to the sum of L_1 , L_2 and L_3 . These models are classified into 5 categories.

1. I-type; distal lengths are larger than those of the proximal,
2. D-type; distal lengths are less than those of the proximal,
3. M-type; middle link (i.e. L_2) is longer than the others,
4. V-type; middle link is shorter than the others,
5. K-type; three links are the same length.

Figure 5 illustrates this classification by segmenting the plane whose horizontal and vertical axes represent proportions

of L_2 and L_3 , respectively. This figure makes it easy to see which type a model belongs to.

C. Dimensions of Objects for Grasping

If we were considering the grasping of objects in three-dimensional space, we would use objects like a ball, a cylinder and a four-cornered pillar. However, since our finger moves in one plane, we can simulate calculations for the stability of the grip reliably by using two-dimensional shapes. For simplicity, we exclude rhomboids and ellipses and restrict ourselves to considering circles, squares and rectangles. The ratio of the long side to the short side of the rectangles is set as $3^{1/2}$. Dimensions of the finger are $L_0 = L_p = 80\text{mm}$ and $\mu = 1.8$. The radii of the circles are chosen from 25mm to 70mm in increments of 2.5mm. The diagonal lengths of the squares and rectangles are from 50mm to 140mm in increments of 10mm. All of these shapes satisfy the conditions of equations (2) and (3) in Section II-A. Under these conditions, grasplings of circles, squares and rectangles are simulated.

D. Simulation Process

This section explains in detail how the simulation of grasping circles is performed. At first, a circle is placed at the left side of the palm to touch the link L_p . Then, the auxiliary link L_0 closes to find the angular displacement θ_0 at which link L_0 touches the circle. When contact is made between the object and link L_0 , link L_1 is driven next, and then L_2 and L_3 , according to the rules described in Section III-A. For stable grasping we impose a tactual condition that the total number of points of contact on L_1 , L_2 and L_3 is greater than or equal to two. Figure 6 shows an example of finger configurations satisfying the tactual conditions for circles. When this condition is satisfied, the wrap-up rate W_r is calculated. The grasping is then evaluated by the magnitude of the wrap-up rate; that is, the grasping is regarded as a stable grasping when the magnitude is greater than a threshold value $(W_r)_t$. In our simulation we set $(W_r)_t = 0.8$.

The same circle is then shifted to the right by $dl = 2\text{mm}$ along L_p and the next check is performed in the same manner. When

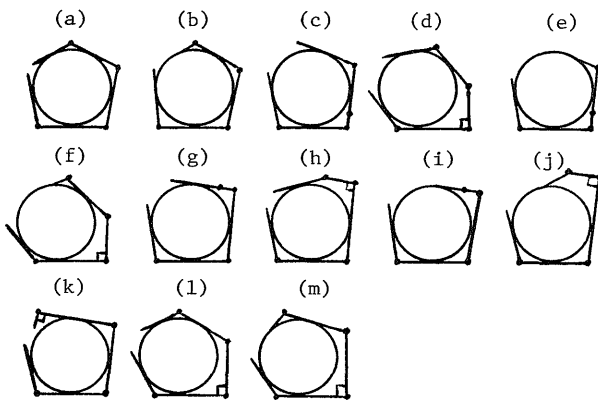

Figure 6: Finger configurations to explain tactual conditions for circles.

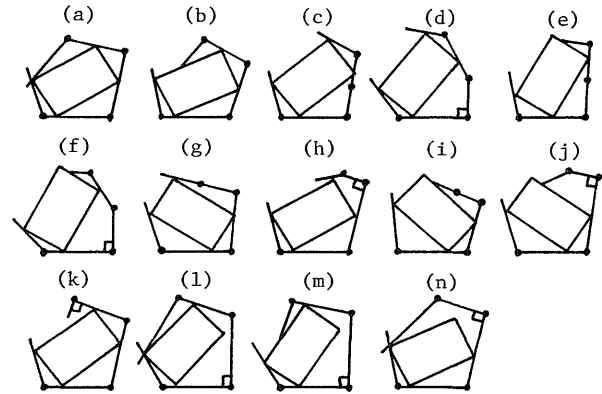

Figure 7: Finger configurations to explain tactual conditions for rectangles.

the contact is made on the tip of L_0 , or the tactual conditions are not satisfied, the data are not taken into consideration and we examine the next grasping. When the circle is moved to the right end of the palm, the next circle having a different size is tested. Many circles of different sizes are tested in different positions relative to the palm, and the total number of grasplings which are regarded as stable grasplings are obtained.

For other shapes, simulations of grasping are performed in ways similar to those for circles. The only difference is that rotations of those figures are also considered by rotating the shapes about their centers as well as moving the position along the palm L_p . The range of rotation is $\pi/2$ and π for squares and rectangles, respectively, and the increment of rotation is $d\rho = 2$ degrees. Finger configurations shown in Figure 7 illustrate the stable tactual conditions for rectangles.

E. Simulated Results

Figure 8 summarizes the simulation results for the case in which we limit the rotational range of the proximal joints to half way, i.e., $0 < \theta_0 < \pi/2$ and $0 < \theta_1 < \pi/2$. Fig.8(a) shows the score of stable grasplings for circles. In the figure, horizontal and vertical axes are proportions of L_2 and L_3 , respectively, and thus each grid position corresponds to each finger model in Table 1. The size of the circle is proportional to the number of stable grasplings. The threshold of the stable wrap-up rate we used is $(W_r)_t = 0.8$. Triple circles indicate the finger model with the most stable grasplings: Double circles indicate the model with the second most stable grasplings. Similarly, Fig.8(b) and (c) show the simulated results for the squares and rectangles, respectively. Fig.8(d) shows the result when the score of stable grasplings for both squares and rectangles are combined. The results shown in Fig.8 imply that the most stable finger model for circles and rectangles is the M-type (refer to Fig.5).

By selecting two models with high stability for both circles and rectangles, those finger constructions shown in Figure 9 are extracted for stable grasping of various shapes. In the figure, (a) shows the result where $(\theta_0)_{max} = (\theta_1)_{max} = \pi/2$, (b) shows the result where $(\theta_0)_{max} = \pi/2$ and $(\theta_1)_{max} = \pi$, (c) shows the result

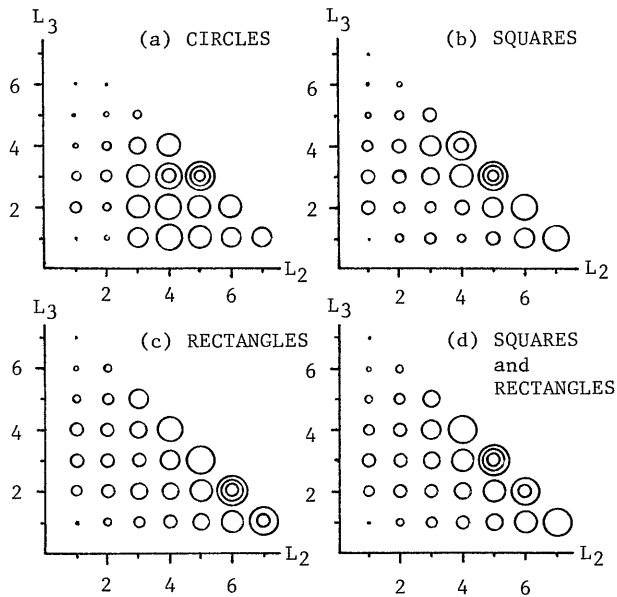

Figure 8: Simulated results of grasplings under $(W_p)_1 > 0.8$, $0 < \theta_0 < \pi/2$ and $0 < \theta_1 < \pi/2$.

where $(\theta_0)_{max} = \pi$ and $(\theta_1)_{max} = \pi/2$, and (d) shows the result where $(\theta_0)_{max} = (\theta_1)_{max} = \pi$. The left finger is the auxiliary link used in the simulations. The next two couples from the left to the right correspond to the appropriate fingers for circles and rectangles, in this order. Hatched and dotted areas show the most proximal and the most distal links (L_1 and L_3), respectively.

By comparing the four finger constructions in Fig.9, it is observed that the lengths of L_3 are not very different from each other, but the lengths of L_1 in (a) are much smaller than in the other three. Also, L_2 in (a) and L_1 in (b) are longer than any other three. Fig.8(a) implies that the M-type model is the most suitable for grasping circles, squares and rectangles when $0 < \theta_0 < \pi/2$ and $0 < \theta_1 < \pi/2$. However, when the auxiliary link or the proximal joint can be bent extensively (that is, the range of θ_0 and θ_1 is enlarged from $\pi/2$ to π), the D-type model is useful for circles and the V-type for squares and rectangles. In general, when the ranges of motion of θ_0 and θ_1 become large at the same rate, the appropriate length of L_1 becomes larger without changing the lengths of L_3 .

Simulations have also been carried out with different tactual conditions such those under which the finger makes contact with the object only on L_3 (except the tip) and only on L_2 . However, no significant difference has been observed between the results for these conditions and those for the ones previously discussed.

IV CONCLUSIONS

We have proposed the wrap-up rate as a criterion for evaluating the stability of grasping by multijointed fingers. In the simulation of grasping, a multijointed finger having three joints is used and circles, squares and rectangles are considered as possible shapes of an object. Positions and orientations of these two-dimensional shapes are changed systematically to examine

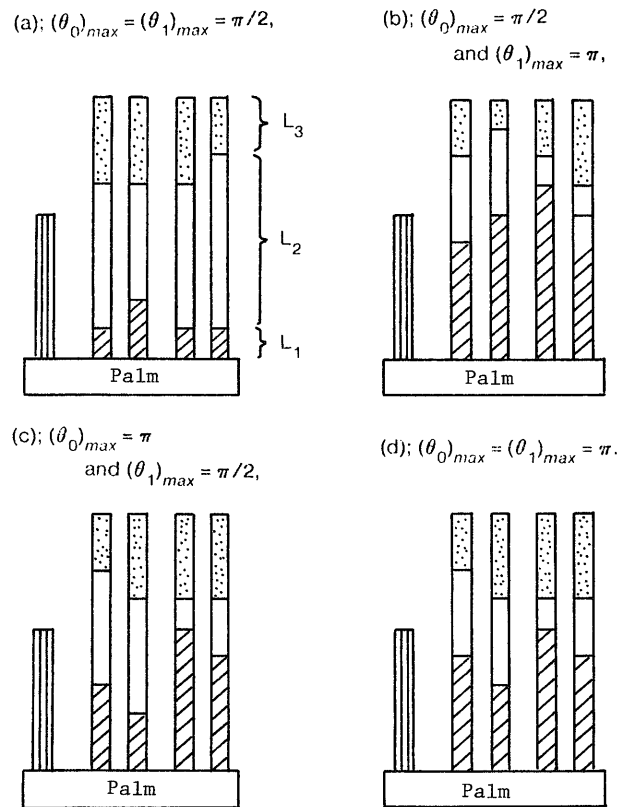

Figure 9: Appropriate finger lengths between phalanges for grasping circles, squares and rectangles.

various grasplings. From the simulation, we have found that appropriate finger lengths between phalanges depend on the angular ranges of proximal joints. The results obtained from the simulation would be useful for determining the lengths between phalanges of multijointed fingers.

ACKNOWLEDGEMENTS

We thank D.R. Reddy for encouraging us to do this research.

REFERENCES

- [1] Asada, H. "Studies on Prehension and Handling by Robot Hands with Elastic Fingers." D.E. Thesis, Kyoto Univ., April, 1979.
- [2] Rovetta, A. and I. Franchetti, "On a General Prehension Multipurpose System." In *Proc. ISIR-80*, Milan, Italy, March, 1980, pp.191-201.
- [3] Okada, T. "Computer Control of Multijointed Finger System for Precise Object-Handling." *IEEE Transactions*, SMC12:3 (1982) 289-299.
- [4] Salisbury, J.K. "Kinematic and Force Analysis of Articulated Hands." Ph. D. Thesis, Stanford Univ., July, 1982.
- [5] Chen, F.Y. "Force Analysis and Design Considerations of Grippers." *Industrial Robot* 9:4 (1982) 243-249.
- [6] Okada, T. "An Artificial Finger Equipped with Adaptability to an Object." *Bul. Electrotech. Lab.*, 37:12 (1973) 1078-1090.