

Constructing Human-Automation Interfaces: A Formal Approach

Michael Heymann

Department of Computer Science
Technion, Israel Institute of Technology
heymann@cs.technion.ac.il

Asaf Degani

Computational Sciences Division
NASA Ames Research Center, California
adegani@mail.arc.nasa.gov

Abstract

In this paper we present a formal methodology and an algorithmic procedure for constructing human-automation interfaces and corresponding user-manuals. Our focus is the information provided to the user about the behavior of the underlying machine, rather than the graphical and layout features of the interface itself. Our approach involves a systematic reduction of the behavioral model of the machine, as well as systematic abstraction of information that displayed in the interface. This reduction procedure satisfies two requirements: First, the interface must be correct so as not to cause mode confusion that may lead the user to perform incorrect actions. Secondly, the interface must be as simple as possible and not include any unnecessary information. The algorithm for generating such interfaces can be automated, and a preliminary software system for its implementation has been developed.

Introduction

In many of today's automated systems, humans are still responsible for monitoring the behavior of the system. Aircraft pilots, medical technicians, and engineers are among the many users who interact with automated control systems to achieve specified operational tasks (Parasuraman et al 2000). These may include (1) monitoring a machine's mode changes during an auto-land, (2) executing specific sequences of actions for setting-up a medical radiation machine, and (3) preventing a system from reaching unsafe states.

Automated control systems such as autopilots and flight management systems exhibit extremely complex behaviors. These are large systems that react to external events, internal events, as well as user-initiated events. For the user to be able to monitor the machine and interact with it to achieve a task, the information provided to the user about the machine must, above all, be correct. In principle, correct interaction can always be achieved by providing the user with the full detail of the underlying machine behavior, but in reality the sheer amount of such detail is generally impossible for the user to absorb and comprehend. Therefore, the machine interface and related user-manuals are always a reduced, or abstracted, description of the machine's behavior. Naturally, we prefer interfaces that are simple and straightforward. This reduces the size of user-

manuals, training costs, and perceptual and cognitive burdens on the user.

In automated control systems such as autopilots and other aircraft systems, the criteria for selecting the information that must be provided to the user (as well as information that can be abstracted away), are currently based only on engineering and human-factors judgments. The decisions are then evaluated in a series of laboratory tests, expensive simulations, and flight-tests. When errors are detected, costly changes must be made, and the system must be re-evaluated. Furthermore, the certification process of proving that an interface design is safe and efficient places a heavy burden on manufacturers. For example, the new regulation and FAA Advisory Circular on Flight Guidance Systems requires that the applicant prove that the system is devoid of confusing modes and related human-automation problems (Federal Aviation Regulation 25.1329).

Despite the best efforts of engineers and hundreds of hours of tests and simulations, interface errors may go undetected because simulation and tests can never fully examine all the possible modes and state combinations. The operational community is well aware of the consequences of these errors: There are hundreds of narratives in the Aviation Safety Reporting System (ASRS) database describing incidents in which pilots find themselves confused and unsure what the machine is doing (ASRS 1998, Vakil et al 1995). There are also several airline accidents in which inadequate interfaces were cited as a contributing factor (ICOI 1992, NTSB 1997). In a recent fuel-starvation incident that resulted in a dead-stick approach and landing by a commercial jetliner at Lajes Field, Azores Islands, there are preliminary indications that the fuel system interface may have been overly complex and misleading (Aviation Week 2001).

In a recent paper (Degani et al 2002), we presented an approach and methodology for verifying interfaces and user-manuals. The methodology evaluates whether the interface and user-manual information are correct and free of errors, given a description of the machine, the user's task, an interface, and a user-manual. The procedure can be automated and used in the verification of complex human-automation systems.

In this paper we take an additional step and discuss a general approach for constructing correct and succinct interfaces. The algorithm presented here is suited for auto-

mated machines that can be described as a system of states. To illustrate the approach and algorithm, we use a simplified version of a transmission system in a road vehicle. Efforts are currently under way to apply the methodology to a portion of the flight management system. A more detailed treatment of this topic can be found in a recent NASA Technical Memorandum (Heymann et al 2002).

Formal Aspects of Human-Machine Interaction

In analyzing human automation interaction from a formal perspective, we consider four major elements: (1) the behavior of the machine (its modes and states), (2) the operational tasks (knowing which mode the machine is in), (3) the interface (the mode annunciations), and (4) the user's model of the machine's behavior (the information in the Aircraft Operating Manual).

Machine

Our focus in this paper is on automated machines that can be described as a system of states. A state represents a mode, or a configuration, of the machine. The machine transitions from one mode to another. Some of the transitions are triggered by the user; for example, the pilot switches from Flight Level Change to Vertical NAVigation mode. Other transitions are automatic and are triggered either by the machine's internal dynamics (e.g., timed transitions – if there is no pilot response within 30 seconds, then the machine switches automatically to another mode), or by the external environment (e.g., sensed transitions – if the outside temperature is below 32 Fahrenheit, then the machine switches automatically to another mode).

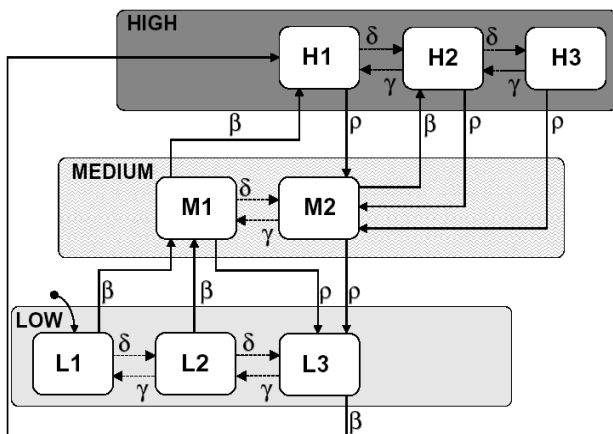

Figure 1. Transmission system.

In the models described here, we always depict user-triggered transitions by solid arrows, while automatic transitions are dashed. The transitions are labeled by Greek symbols indicating the events under which the machine moves from state to state.

The machine in Figure 1 describes a simplified three-speed transmission system of a vehicle. The transmission has eight states (representing internal torque-levels). These are grouped into three speed modes: LOW, MEDIUM, and HIGH. States L1, L2, L3 are in the LOW speed mode; M1, M2 in the MEDIUM speed mode; and H1, H2, H3 in HIGH.

The transmission shifts up and down either automatically (based on throttle, engine, and speed values) or manually (by pushing a lever). Manual up-shifts are denoted by event b and down-shifts by event r . Automatic up-shifts are denoted by event d , and automatic down-shifts by event g .

User's Task

The second element of our framework is the user's operational tasks, which in case of the transmission, consists of tracking the three speed modes unambiguously. In other words, the user must be able to determine the current mode of the machine and predict the next mode of the machine. This requirement is akin to the type of questions pilots usually ask about automated cockpit systems such as autopilots and flight management systems: "What's it doing now?" "What's it going to do next?" and "Why is it doing that?" (Wiener 2002).

We can describe the user's task by partitioning the machine's state-set (the 8 internal states in Figure 1) into distinct clusters, or modes. In the transmission system there are three such clusters: LOW, MEDIUM and HIGH. Note, however, that the user is required to track only the modes and not every individual state of the machine (e.g., transitions between states M1 and M2 inside MEDIUM).

Interface

The interface commonly consists of two components: (1) a control panel through which the user enters commands and, (2) a display through which the machine presents information to the user about the status of the machine. The status display shows, for example, the active mode, the armed modes, as well as the events that take place.

As discussed earlier, the interface generally provides the user with a simplified view of the machine. In almost any display, especially those for automated systems, many of the machine's internal events and states are hidden from the user: Otherwise, the size of cockpit displays, for example, would be colossal. Hence the display provides only partial information about the underlying behavior of the machine. The cardinal issue, therefore, is which information can be safely removed or abstracted, and which must not.

Figure 2 describes the control panel and one proposed display for the transmission system, where the user expects to be switching among the modes (LOW, MEDIUM and HIGH), by pushing up or down on the gear lever. Note that in this display, all the internal states (e.g., L1, L2, ...to H3) are suppressed from view.

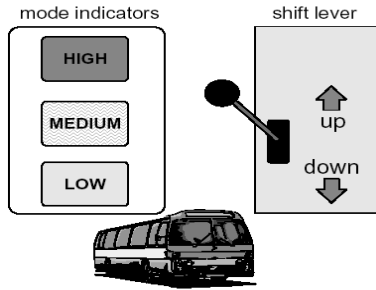

Figure 2. Display and control panel.

User Model

Manufacturers normally provide users with information about the working of the machine in the user-manual (e.g., Aircraft Operation Manual, Flight Crew Operations Manual) that describe the behavior of autopilots. Most verbal statements in the Aircraft Operational example, have the following form: “when the autopilot is in mode X and button ‘k’ is pushed, the autopilot engages in mode Y.” Similarly, the user-manual for the transmission system tells the driver that when the transmission is in LOW mode, pushing the lever up (and triggering event b) will cause the system to shift to MEDIUM mode. When in MEDIUM mode, a shift up will give HIGH, and so on. This series of fragmented statements describe how to operate the machine. But again, note that these statements are also a simplification of the actual behavior of the machine; a lot of information about the machine’s internal events has been omitted. If this were not the case, the size (and weight) of operating manuals would be huge.

In practice, the user-manual is written based on the display. This is naturally so because the operating manual explains and constantly refers to the display. It is therefore possible to combine the user-manual information with the display to create a model, as shown in Figure 3. In this way, the display (Figure 2) is “embedded” in the user-model, and we can prudently continue the analysis without having to consider the interface separately.

To summarize, what is being removed from the interface, user-manual, and consequently from the user’s awareness is the automated internal transitions that take place within each mode, or gear. For example, the LOW mode has three possible internal states, L1, L2, L3. When the user first up-shifts manually into LOW gear, L1 is the active state until a certain combination of throttle, engine, and speed is reached. At this point there is an automatic transition to L2. This internal transition is not evident to the driver-user, who is aware only of being in LOW. The question is how much of the internal information must be presented to the user in order to be able to operate the machine correctly?

Evaluation Of Interfaces

Now let us evaluate the user-model described in Figure 3. This suggested user model is a very simple one and seems intuitively clear: The display shows only the three modes (LOW, MEDIUM, and HIGH). All the internal states of the machine are removed and all the automatic (internal) transitions are suppressed.

Is this a good interface?

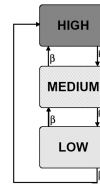

Figure 3. User model.

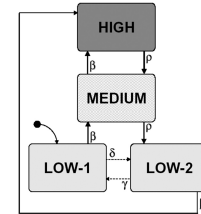

Figure 4. Alternate User model

Let us look at it more carefully. The manual shifts from MEDIUM up to HIGH or down to LOW, as well as the down-shift from HIGH to MEDIUM, are always predictable – the user will be able to anticipate the next mode of the machine. However, the up-shift from the LOW gear depends on the internal state: up-shifts from L1 and L2 transition to MEDIUM mode, while the up-shift from L3 switches the transmission to the HIGH mode. As a consequence, the user will not be able to predict whether the up-shift will lead the transmission from LOW to MEDIUM, or from LOW to HIGH. We therefore must conclude that this user-model (and display) are not adequate for the task.

An alternate user-model that may remedy the above problem is depicted in Figure 4. This modified display shows two LOW modes (LOW-1, LOW-2). The user-manual further explains that the transitions between LOW-1 and LOW-2 occur automatically. The user is told that upon up-shift from LOW-1, the system transitions to MEDIUM, while on upshift from LOW-2, the system goes to HIGH.

Formal Verification Of Interfaces

Again, we ask: is this a good interface?

Well, by intuitive inspection it seems quite reasonable—we have taken care of the problem with the manual up-shift from LOW. But let us apply the verification methodology that was mentioned earlier to confirm it formally. The algorithmic details of this verification methodology and its application to an automated flight control system are provided elsewhere (Degani et al 2002). Here, we will give a brief synopsis of the methodology in the context of the transmission example.

The objective of the verification methodology is to determine whether a given user model (and interface) enable the user to operate the machine correctly. The essence of the procedure is to check whether the user model “marches” in synchronization with the machine

model. This is determined by creating a composite model of the user- and machine-models (see Figure 5).

We assert that a user-model is correct if there exist no error states, no blocking states, and no augmenting states in the composite model. An error state represents a divergence between the machine and user-models. That is, the interface tells the user that the machine is in one mode when in fact the machine is in another. A blocking state represents a situation in which the user can in fact trigger a transition from one mode to another, yet this information is not provided to the user (and when the transition happens, the user is surprised). An augmenting state is a situation in which the user is told that a certain mode change is possible, when in fact it may be the case that the machine will not switch into this mode or sub-mode.

Let us apply this methodology to verify whether the alternative user-model of Figure 4 is correct. The machine (of Figure 1) starts in state L1 and the user-model (of Figure 4) starts in LOW-1. So the first composite state is "L1, LOW-1." Upon an automatic up-shift transition (event d), the machine transitions to L2 and the user model to LOW-2. Now we are in composite state "L2, LOW-2." Another automatic up-shift (event d) and we are in "L3, LOW-2." Now if the user pushes the up shift-lever (event b) the machine transitions to H1 and the user model also goes to HIGH, and everything is okay. The user-model runs in complete synchronization with the machine model.

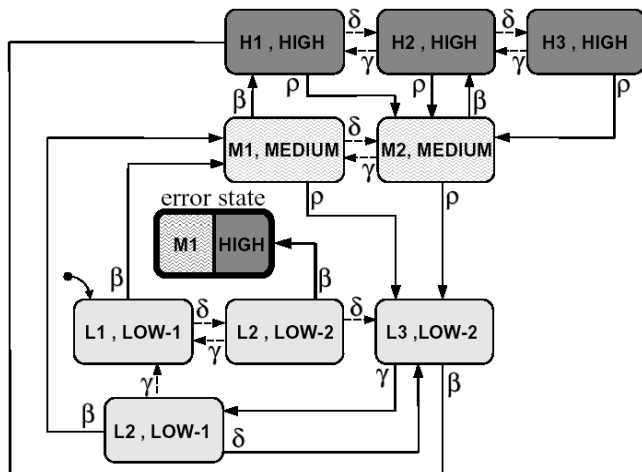

Figure 5. Composite model of the alternative user model.

Recall that the user-model is aimed at enabling the operator to determine unambiguously which speed-mode the transmission is in, or is about to enter. With this mind, look at the following sequence: we start as before in "L1, LOW-1". Automatic up-shift (event d) takes place and now we are in the composite state "L2, LOW-2." The user now decides to use the manual up-shift gear. The machine (according to Figure 1) will transition to state M1, yet according to the user-model of Figure 4, we are now in HIGH mode. The new composite state is "M1, HIGH." This, of course, is a contradiction!

The user thinks he is in HIGH mode where in fact the underlying machine is in MEDIUM (state M1). The resulting ambiguity is a classical mode error (Norman 1983). We therefore must conclude that the user model of Figure 4 is also incorrect and work on finding another alternative.

It is of course possible to concoct other user-models and then iteratively employ the verification procedure to determine their correctness. However, such an effort is not likely to be very efficient: it may take considerable effort to develop and verify one design after another, with no guarantee of success. Furthermore, even when a correct interface is identified, there is no assurance that it is the simplest possible; there could be an equally good, or even better abstraction, hiding just around the corner. The development of a systematic approach for constructing interfaces that are both correct and succinct is the subject of the next section.

Machine Model Reduction

As mentioned in the Introduction, one possible choice of user-model is to display all the internal states of the machine. This will insure that there is never any problem in predicting the next state of the machine. And therefore there will never be an error state. But the display size will be unimaginably large, the user manuals weigh tons, and the human operator overwhelmed.

So our objective becomes clearer: to generate the best possible user-models and interfaces that will allow the operator to perform tasks safely. By best user models and interfaces we mean ones that cannot be further reduced and simplified. To accomplish this, we take the machine model of Figure 1 and reduce it systematically with reference to the task requirements.

The proposed reduction procedure, which computes all possible irreducible user-models, is a formal mathematical process that consists of several computational steps. In the first step, compatible sets of internal states are computed. These are sets of states that, in principle, can be grouped together to form super states. These super-states have the property that individual state inside them need not be distinguished by the user. The sets of compatible states are successively enlarged until maximal compatible sets are obtained that cannot be further enlarged.

The second computational step consists of selecting a suitable subset of the set of maximal compatibles that can form a state set of a reduced model. This selection process is generally not unique, and there may be more than one choice. Each choice will yield a different user-model and interface. The ultimate choice must be based on engineering and human-factors considerations of the designers. Finally, the last step consists of constructing the abstracted user-model and interface (that are associated with a particular choice).

In the next sub-sections we shall describe in some detail how the computation of reducing the machine model is carried out. We re-emphasize that the computation is formal and rather technical. The reader who is not inter-

ested in learning the detailed computational steps, may wish (at least on first reading) to skip to the next section and see the results of the formal computation and how the new user-model (and interface) are constructed.

Compatible States

We mentioned earlier that the user-model must enable us to operate the system correctly with respect to the user's task(s). In our example, the user-model must allow the operator to track the machine as it switches from one mode to another. But we have already learned there is no requirement that the user track every internal state of the machine. There is no need for us to distinguish between two internal states (say M1 and M2 of mode MEDIUM), if, after following any given event sequence, we end up in the same mode (e.g., HIGH, MEDIUM or LOW), regardless of which of the two states we started in. If that's the case, we say that the two states (M1 and M2) are compatible. Two compatible states can be grouped together in the abstracted model--there is no need to distinguish between M1 and M2 in the interface.

Trying to find state pairs that are compatible is difficult, instead let's turn our attention to state-pairs that are incompatible. If we can compute all incompatible pairs (that cannot be grouped together), the remaining pairs must be compatible. Incompatible pairs are, for example, two states that belong to two distinct modes. Thus, the state-pair L1 and H3 is incompatible: L1 belongs to mode LOW and H3 belongs to mode HIGH. We must never group them together on the display; for otherwise we create an error-state. Another reason for deeming a pair of states incompatible is if a transition out of one of the states and the same transition out of the other, lead us, respectively to two states of a pair that was already deemed incompatible.

Identifying Compatible Pairs

Now we proceed to identify all the compatible (and incompatible) pairs in the machine model. Once we identify compatibles, we can group them together, abstract them, and ultimately reduce the display complexity. See (Kohavi 1978, Paull et al 1959) where related model reduction procedures are discussed.

Using the above observations regarding compatible and incompatible pairs, we proceed as follows to create the *initial resolution*.

1. For each state pair (e.g., L1 and H3) that can be immediately determined as incompatible (because they belong to two distinct modes – LOW and HIGH), we mark the corresponding cell **I** (for Incompatible).
2. For all other state-pairs, we write in their cells the next transition pair. For example, for the state pair (M1,M2) the next transition pair, after initiating the common event b, is (H1,H2).

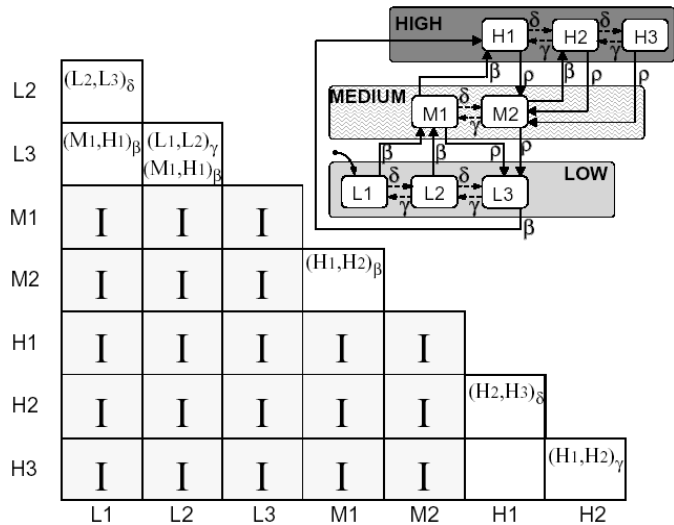

Figure 6. Initial resolution.

Initial Resolution

Figure 6 shows a table of all possible state-pairs for the transmission system (there are 28 such pairs), as well as the initial resolution. To explain how we get this initial resolution let's start at the top (the machine model is provided so that the reader can follow the process): The state pair (L1, L2), transitioned on automatic up-shift d to the pair (L2, L3). And that's what we write inside the top cell. The state pair (L1, L3) transitions into (M1,H1) on manual up-shift b. However, from (L2, L3) there are two possible transitions: automatic down-shift g takes us to (L1,L2), and manual up-shift b takes us to (M1,H1). So we place these two transition pairs in the cell of L2 and L3. (M1,M2) takes us to (H1, H2) on manual up-shift b (in the table we write the triggering event as a subscript for the reader's convenience). And so on. Notice, however, that the cell H1,H3 is empty. This is because it is neither incompatible nor it has associated transition pairs.

Second Step

We now continue with the reduction process. But from this step onward, we do not need to refer to the machine model anymore. We simply start substituting values in the cells according to the following procedure:

1. Cells that are incompatible stay that way (**I**). Every cell that has not yet been determined as **I** in Figure 6 (e.g., L1,L3) is updated as follows: If a cell includes a transition pair (e.g., M1,H1) that has already been determined to be incompatible (**I**), then the harboring cell is also denoted **I** (see Figure 7).
2. Otherwise, the cell is modified as follows: Each transition pair in the cell is replaced by all the transition pairs that appeared in their original cell. For example, the cell of (L1,L2) contains the transition pair

$(L2,L3)_b$. We look into cell $(L2,L3)$ and find in there the state-pairs $(L2,L3)_g$ and $(M1,H1)_b$. We place them in $(L1,L2)$.

L2	$(L1,L2)_g$ $(M1,H1)_b$						
L3	I	I					
M1	I	I	I				
M2	I	I	I	$(H2,H3)_\delta$			
H1	I	I	I	I	I		
H2	I	I	I	I	I	$(H1,H2)_\gamma$	
H3	I	I	I	I	I		$(H2,H3)_\delta$
	L1	L2	L3	M1	M2	H1	H2

Figure 7. Second reduction step.

Figure 7 shows the table after the completion of the second step. First, we replaced the transition pairs in the cell $(L1,L2)$ by those in the cell $(L2,L3)$. The cells $(L1,L3)$ and $(L2,L3)$ were denoted as **I** because their cells include incompatible pairs. The remaining undecided state pairs (those that have not yet been given the value **I**) were modified according to the above procedure. For example, in the cell $(M1,M2)$ we placed the transition pair $(H2,H3)_d$.

Third Step

In the third step the table shown in Figure 8 is obtained. Here cell $(L1,L2)$ is marked **I** because one of the transition pair inside it-- $(M1,H1)_b$ --is incompatible. The remaining undecided cells are modified as specified by the procedure.

Fourth Step

In this step we realize that no additional incompatible pairs are identified, and the table remains identical to that of Figure 8. At this point, no further iterations will ever produce an **I**. Therefore, all the undecided cells are marked **C** (for compatible) as in Figure 9. This concludes the resolution procedure and the determination of all incompatible and compatible pairs.

Computing all Compatible Sets

Following the computation of all compatible pairs, we must compute all compatible triples, quadruples, etc., until no new compatibles are found. The computation is based on the observation that a set of states is compatible if all its constituent pairs are compatible (Heymann

et al. 2002). This means that a state triple is compatible if its three constituent pairs are compatible, a state quadruple is compatible if its four constituent triples are compatible, and so on.

L2	I						
L3	I	I					
M1	I	I	I				
M2	I	I	I	$(H2,H3)_\delta$			
H1	I	I	I	I	I		
H2	I	I	I	I	I	$(H1,H2)_\gamma$	
H3	I	I	I	I	I		$(H2,H3)_\delta$
	L1	L2	L3	M1	M2	H1	H2

Figure 8. Third reduction step.

L2	I						
L3	I	I					
M1	I	I	I				
M2	I	I	I	C			
H1	I	I	I	I	I		
H2	I	I	I	I	I	C	
H3	I	I	I	I	I	C	C
	L1	L2	L3	M1	M2	H1	H2

Figure 9. Completed reduction table.

Creating the User-Model

Not every compatible set is a good candidate of a succinct user model. If a compatible set is contained within a bigger compatible set, we might as well choose the bigger one as a better candidate. Thus, we are actually interested only in the maximal compatibles that are not contained in any bigger compatible set. In general, there are many maximals. To create a base state-set for a reduced model, we must choose from the set of maximal compatibles judiciously. We must insure that our selection is such that each state of the machine model is represented in at least one of the selected maximal compatibles. But we do not want redundancy. In particular, we do not want to be able to eliminate any maximal compatible from our selection without destroying the full representation requirement. Such a set of maximal compatibles is called a minimal cover. Thus, a minimal cover of maximal compatibles, forms a set of states for an efficient user-model.

Constructing the Interface

Figure 9 shows that the compatible pairs (C) consists of the two internal states in MEDIUM mode (M1,M2) as well as all the possible state-pairs in HIGH ((H1,H2), (H1,H3), and (H2,H3)). The results tell us that we do not need to display the two internal states in MEDIUM, and none of the three internal states in HIGH. And what about LOW mode? Since L1, L2 and L3 do not appear in any compatible pairs, we have no choice but to display them to the user. Figure 10 is our best (i.e., minimal) user-model possible for the machine of Figure 1.

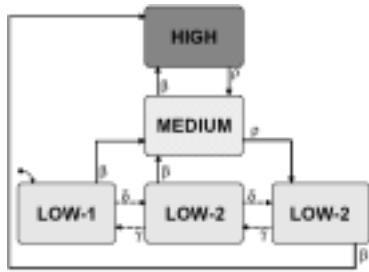

Figure 10. The reduced user model.

Conclusions

The problem of incorrect and overly complex interfaces has plagued the design of human-automation interaction, and still does. Such design problems are responsible, in part, for what has been termed “automation surprises” (Woods 1997). Such surprises occur when pilots have difficulty understanding the current status of an automatic system as well as the consequences of their interactions with it (Degani et al 1999).

In this paper we have shown a methodology and an algorithmic procedure for constructing user-models and interfaces. We have focused on the information content of the display and not on the graphical user interface. Two objectives have guided us in developing the methodology: (1) that the interfaces and user-models be correct; (2) that they be as simple as possible.

This paper has presented the flavor of our approach to constructing correct and succinct user interfaces, and by use of the transmission example illustrated the iterative reduction process, which is at the heart of the methodology. The reader is encouraged to refer to (Heymann et al 2002) for more details.

The methodology presented here deals with discrete-event systems (those that have states and modes). However, the approach is general and therefore amenable to other type of representations. It remains an interesting topic of future research to expand this approach to systems that have both continuous and discrete events (hybrid systems) as well as timed systems. And indeed, promising results in verification of a complex hybrid system (an autoland system of a commercial airliner), have already been obtained.

References

- Aviation Safety Reporting System. 1998. FMC altitude capture function reports. Search Request No. 5183. Mountain View, CA: Battelle Memorial Institute.
- Aviation Week and Space Technology. 2001. Airbus A-330 Fuel System: How It Works and Pilot Choices (March 12, 2001), 34-37.
- Degani, A., Shafto, M., and Kirlik, A. 1999. Modes in Human-Machine Systems: Constructs, representation, and classification. *International Journal of Aviation Psychology*, 9(2), 125-138.
- Degani, A. and Heymann, M. 2002. Formal Verification of Human-Automation Interaction. *Human Factors*.
- Heymann M., and Degani A. 2002. On abstractions and simplifications in the design of human-automation interfaces. NASA Technical Memorandum 2002-211397. Moffett Field, CA. (<http://ic.arc.nasa.gov/publications/number.html>).
- Indian Court of Inquiry. 1992. Report on accident to Indian Airlines Airbus A-320 aircraft VT-EPN at Bangalore on 14th February, 1990. Indian Government.
- Kohavi, Z. 1978. *Switching and Finite Automata Theory*. New York: McGraw-Hill.
- National Transportation Safety Board. 1997. *Wheels-Up Landing of Continental Airlines Flight 1943, Douglas DC-9 N10556, Houston, Texas, on February 19, 1996*. (Report Number: AAR-97-01). Washington DC: NTSB.
- Norman, D. A. 1983. Design rules based on analysis of human error. *Communications of the ACM*, 26(4), 254-258.
- Parasuraman, R., Sheridan, T.B., and Wickens, C.D. 2000. A model for the types and levels of human interaction with automation. *IEEE Transaction on Systems, Man, and Cybernetics – Part A: Systems and Humans*, 30(3), 286-297.
- Paull, M.C. and Unger, S.H. 1959. Minimizing the number of states in incompletely specified sequential switching functions. *Institute of Radio Engineers Transactions on Electronic Computers*, 356-367.
- Vakil, S., Hansman, R. J., Midkiff, A. H., and Vaneck, T. 1995. Mode awareness in advanced autoflight systems. In T. B. Sheridan (Ed.), *Proceeding of the International Federation of Automatic Control; Man-Machine Systems (IFAC-MMS) Conference*. Boston, MA: IFAC.
- Wiener, E.L. 2002. Personal communication, April 5.
- Woods, D., Sarter, N., and Billings, C. 1997. Automation surprises. In G. Salvendy (Ed.), *Handbook of human factors and ergonomics (1926-1943)*. New York: John Wiley.